

*Volution 2 Compact  
Volution 2 Macro*

***VOLUTION<sup>2</sup>***



WARNING!!! Use of the Parajet powered paraglider is at your own risk.

**WARNING!!!**

**YOU MUST READ THIS MANUAL AND AGREE TO THE CONDITIONS OF USE BEFORE USING YOUR PARAJET VOLUTION 2**

Bear in mind that you will use the Parajet Volution 2 and paraglider at your own risk. Due to the inherent risk in flying the Volution 2 or any motorized paraglider, no guarantee of any kind can be made against accidents, bodily injury and/or death. Be sure, therefore, to make all required checks on the power unit and paraglider before every flight. Never try to fly if you find any part of your Volution 2 damaged or suspect a malfunction.

***NB. This manual is NOT a substitute for flight training. Proper training is essential.***

**INTRODUCTION**

Congratulations on the purchase of your Parajet Volution 2 for motorized paragliding. We guarantee you have made an excellent choice and wish you many enjoyable flights and just as many safe landings with your Volution 2.

Our power units have been designed and produced in our UK factory to exacting standards. Each Volution 2 is carefully inspected before leaving the factory. This manual and Parajet power unit carry a placard that clearly indicates a limit to flight hours. Therefore, use your Volution 2 within the limits indicated.

Should the purchaser modify the Volution 2 so as to change its original specifications, the manufacturer's warranty becomes invalid.

Please read and be sure that you thoroughly understand this manual before flying the Volution 2. If there is any terminology or anything else in this manual which you do not understand, please contact your dealer for clarification.





WARNING!!! Use of the Parajet powered paraglider is at your own risk.

## Contents

WARNING!!! .....	2
Contents.....	3
PRE-FLIGHT CHECKS.....	4
FLIGHT SAFETY PRECAUTIONS.....	5
SOME GOLDEN RULES !!! .....	6
PRE-ASSEMBLY CHECK .....	7
List of Components .....	7
FITTING THE PROPELLER BLADES .....	8
ASSEMBLING THE 3-PIECE PROPELLER GUARD.....	9
Charging the Volution 2 LiPo battery: .....	<b>Error! Bookmark not defined.</b>
REDUCTION BELT ADJUSTMENT.....	11
FITTING THE WEIGHT-SHIFT HARNESS .....	12
ADJUSTING THE WEIGHT SHIFT HARNESS .....	13
MIXING FUEL AND OIL .....	14
FILLING THE FUEL TANK .....	14
Caution!.....	14
PRIOR TO STARTING THE ENGINE .....	15
Warning!!! - Stay Clear of this Area !!!.....	15
STARTING THE ENGINE .....	16
ACTIVATING THE CHOKE VALVE .....	17
CARBURETOR ADJUSTMENT .....	18
CARBURETOR ADJUSTMENT (continued).....	19
CARBURETOR ADJUSTMENT (continued).....	20
ENGINE RUNNING IN PROCEDURE .....	21
PARAJET VOLUTION 2 SPECIFICATIONS.....	22
Propeller and Cage Guard.....	22
Engine Specifications.....	22
MAINTENANCE SCHEDULE .....	23
EVERY 5 HOURS.....	23
EVERY 10 HOURS.....	23
EVERY 50 HOURS.....	23
TROUBLE SHOOTING.....	24
STORAGE FOR A LONG PERIOD AND USE THEREAFTER.....	25
When your engine has not been used for more than 4 weeks.....	25
When the engine is not used for more than 3 months.....	25





WARNING!!! Use of the Parajet powered paraglider is at your own risk.

## PRE-FLIGHT CHECKS

(every 5 – 10 hours of flying)

1	Frame/ Prop Guard	Check for loose bolts/nuts or cracks. Check all netting is intact.
2	Harness	Check all belts, material for tears, worn or burnt parts of harness.
3	Propeller	Check for cracks, chips in blades; sufficient prop and guard clearance; loose or missing prop bolts/nuts. Check prop bolts are tightened to <b>20 Nm</b> .
4	Gas tank	Remove cap, check inside and outside for cracks and holes. Check bolts are tight on top of tank. Check fuel line for scuffs or kinks. Remove dirt or change filter if blockage is discovered.
5	Crankshaft	Turn prop slowly, listen for compression and check for “grinding metal” sound
6	Reduction unit	Check for loose bolts and excess play in propeller shaft bearings.
7	Reduction belt	Check for proper tracking, belt squarely in Pulley track. Look for cracks or worn spots on belt.
8	Cylinder head Crank case	Check for cracks and oil leakage.
9	Spark plugs	Check gap clearance (0.8 mm ± 0.1) check for burnt electrodes and carbon deposits. (every 10 hours)
10	Throttle lever	Throttle lever/cable move smoothly and return.
11	Kill switch	Button depresses and returns.
12	Starter motor	Pinion gear activates and returns. Grease if necessary.
13	Electrics	Check for broken wires and loose connections.
14	Battery terminals	Check for loose terminals, heat bubbles, corrosion etc.
15	Carburetor settings	Check idling, and full power rpm settings. Adjust as directed in this manual- see Carburetor Adjustments.
16	Eccentric Shaft Retaining Bolt	Check bolt behind driven pulley and tighten to <b>25Nm</b> .

## FLIGHT SAFETY PRECAUTIONS

- The Parajet 2 XT 172 engine has been run-in prior to shipment. This means that your Volution 2 is ready to fly. It is important however that excessive throttle is NOT used for at least the first 10 hours of flying. For example, do NOT depress the throttle fully for more than 30 seconds at a time. A well run in engine will outperform an engine that has been run at full power for long periods right from the start. You can potentially damage a new engine with excessive throttle.
- The Volution 2 Paramotor unit is to be used only after having received adequate and proper training from a qualified motor paragliding instructor.
- Max weight capacities for paramotor pilots flying a Parajet Volution 2 range paramotor:

Parajet Volution 2 Models	Max Pilot Weight
Compact	100Kg
Macro	160Kg

- The Volution 2 should only be used with canopies designed for motor paragliding/ powered paragliding/paramotoring.
- Always conduct a check of all components before every flight.
- Always wear a helmet, flight shoes and gloves when flying the Volution 2.
- Always stay clear of moving parts such as propellers, pulleys and belt.
- Always stay clear of hot engine parts and muffler.
- Do not fly low level over water, woodland, or potentially hazardous landing areas. Do not fly into controlled airspace or over built up areas, it essential always to consider a safe landing area should you experience an engine failure or loss of power.
- Before starting the engine check the area is clear and shout "CLEAR PROP"
- Always ensure that the power unit is switched off when not in use. The main power switch is to be found on the **Right Side** of the machine just behind the harness.



WARNING!!! Use of the Parajet powered paraglider is at your own risk.

## **SOME GOLDEN RULES !!!**

1. Never place your engine downwind of your wing.
2. Have you enough fuel to get there? Better too much than too little!
3. Check for any loose articles that could trail or fall into the propeller while flying and fasten them securely.
4. If you spot a problem, no matter how small, deal with it NOW!
5. Always put on and fasten your helmet before clipping into the harness.
6. Always carry out full pre-flight checks before launching.
7. Don't fly into danger – over water, tree, power lines etc where an engine failure will leave you in trouble.
8. Try not to fly in the turbulence of your own wake or that of others, especially at low altitude.
9. Except for collision avoidance, making a sharp turn against the torque effect during steep climbs can be dangerous: you may rapidly stall and enter a spin.
10. Avoid downwind low flying: it drastically reduces your options.
11. Be sensitive to mechanical problems early. A noticeable change in engine tone or a new vibration may spell trouble. Land and check it out!
12. Remember, not everyone enjoys your engine noise. Care must be taken when flying near livestock.
13. Never take-off towards areas of potential rotor, towards trees or buildings on the lee side of a hill.
14. Never touch any part of the propeller guard when the engine is running.
15. Always be aware of the weather, never fly if large cumulus clouds are brewing and never fly in the rain.
17. Never fly below the lee side of a hill, rotor is dangerous!!



## PRE-ASSEMBLY CHECK

Be sure to identify all components after unpacking your Volution 2 unit. If any parts are found defective do not assemble. Contact your dealer or the manufacturer immediately. Parajet International Ltd: Main enquiry Line + 44 8700 116618

### List of Components

- |                       |                                 |
|-----------------------|---------------------------------|
| 1. Main Chassis       | 7. 3 Piece Propeller Guard      |
| 2. Engine Cylinder    | 8. Carbon Fibre Propeller Blade |
| 3. Drive Belt         | 9. Propeller Retaining Disc     |
| 4. Drive Pulley       | 10. Muffler and Exhaust Pipe    |
| 5. Main On/Off Switch | 11. Fuel Filler Cap             |
| 6. Harness            |                                 |

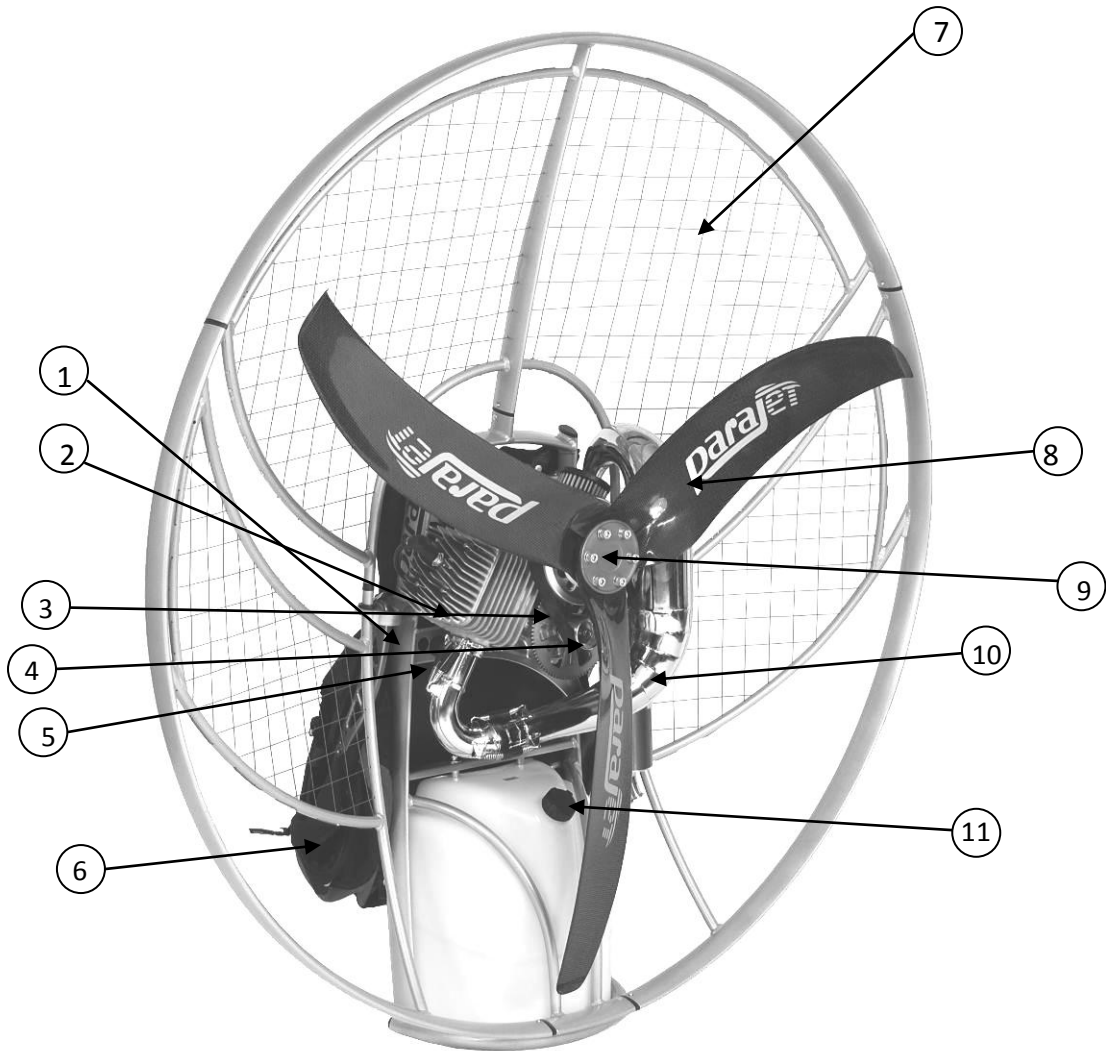

## FITTING THE PROPELLER BLADES

Fit the 3 propeller blades to the driven pulley in the order outlined below

1. Interlink all three propeller sections, being careful to match the dots. (i.e. the sections with three dots should be adjacent to the other blade showing three dots, and so on).
2. Locate the blades in position over the driven pulley with the screws already inserted through the hub plate and props.
3. Screw in each screw by a few turns then move on to the next all the way round the hub plate, repeat this procedure several times until the props are secured.
4. Finally tighten each bolt with equal torque hand tight only (be careful not to over tighten and crush the carbon fibre propeller hubs)

**Note** – When installing the propeller, the propeller blade bolts should not be over-tightened or the base of the propellers could be damaged, distorted and weakened.

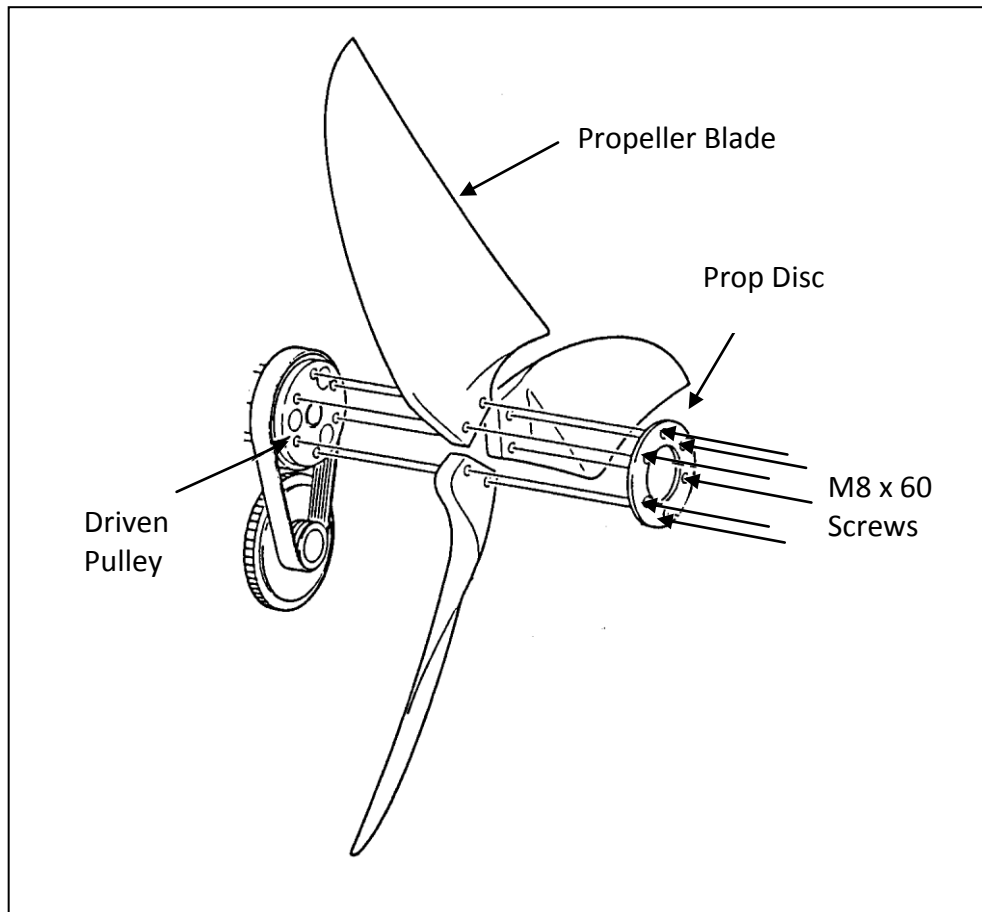

## ASSEMBLING THE 3-PIECE PROPELLER GUARD

Fit the three pieces together as shown in the illustration below. The two lower sections should be clicked into position first. The top section can then be clicked into position, to do this lightly press the curved central support onto its aerofoil connector and simultaneously locate the two circular side connectors. **DO NOT PRESS FIRMLY INTO POSITION UNTIL THE OUTER RING CONNECTORS ARE LOCATED.** Next locate the left and right hand outer ring connectors. Lightly press them into position but do not depress the button clips. Now that all the connection points are in position, the central upright should be firmly pressed into position and the button clip depressed to lock this position. The outer ring connectors can now be locked in also. This process require a little technique, but once developed can be snapped together and disassembled in under a minute. This is the fastest and most durable design of propeller guard. **Note** - The propeller guard is designed to prevent canopy lines and other foreign objects from being drawn into the propeller and are not intended to protect the pilot. Therefore, always use extreme caution and never touch any part of the propeller guard while flying or running the engine on the ground.

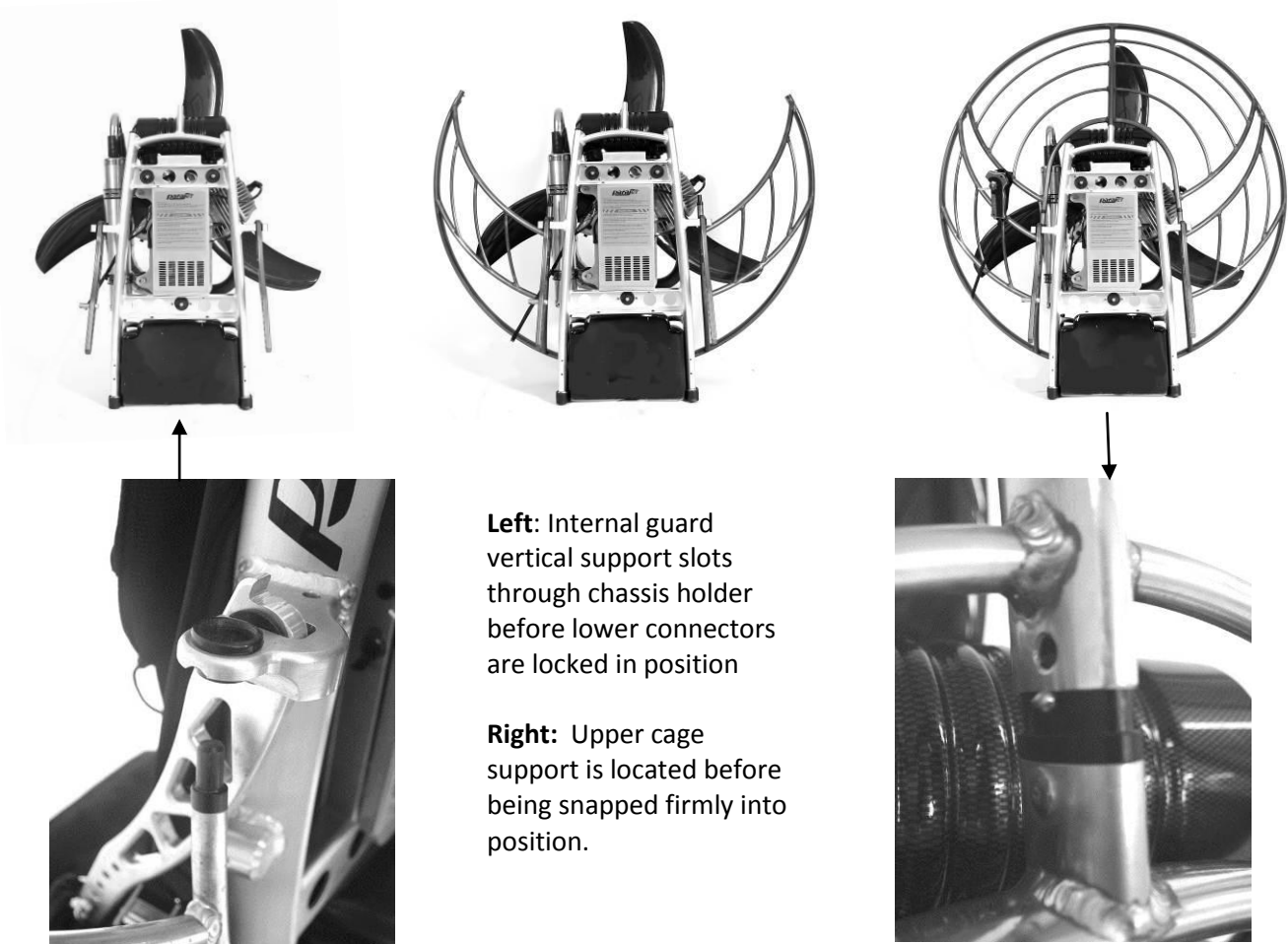

**Left:** Internal guard vertical support slots through chassis holder before lower connectors are locked in position

**Right:** Upper cage support is located before being snapped firmly into position.



WARNING!!! Use of the Parajet powered paraglider is at your own risk.

## **Charging the Volution LiPo battery:**

Important! Caution! Always disconnect the battery connector when not using the Volution for more than 4 days. If you do not you will risk damaging the battery.

**WARNING: Do not try to start your engine if the battery is showing signs of running low. The starter motor will start to spin slower, due to the nature of LiPo batteries they drain very quickly once the voltage drops below a certain level. If you continue to try starting the engine once the battery voltage has dropped you will risk seriously damaging the battery or starter motor. Ideally charge your battery after every flight.**

Your Parajet Volution is supplied with a 11.1volt high power Lithium Polymer battery. This type of battery has the highest energy density of any type of battery available today. It also has many other advantages such as

1. It can be fully charged in under one hour
2. It has an extremely high discharge rate, delivering fully energy to the start motor instantly which results in the easiest start procedure

### Charge procedure

1. Switch on Battery Charger by:
  - a. Plugging in the mains 240volt or 110volt power lead (lead supplied in box)
2. Using the 'Batt Type' button press until 'LiPo' is displayed on the screen
3. Press the 'ENTER Start/Stop' button to set the charging amps and number of cells. Use the Inc + button to set the figures as follows:
4. 4.0A 3CL (The charger must first read these figures to charge correctly)
5. Plug the battery you wish to charge into the charger by first connecting the small white multi pin plug into the 3S socket on the small adaptor board supplied. Then connect the larger blue battery terminal plug to the charger
6. Once both battery connectors are connected press and hold the ENTER Start/Stop button for 3 seconds and the charge and balance procedure will begin.

**IMPORTANT: Stop using the battery once the cranking speed has clearly reduced and re-charge the battery.**

**IMPORTANT: You should charge the battery using the procedure described above every time you charge as this will keep the battery in the best possible condition. This is known as balance charging your battery and it maintains each individual cell within the battery pack from becoming damaged due to voltage imbalance.**



## REDUCTION BELT ADJUSTMENT

The transmission belt is well adjusted at the time of shipment, but it could become slack during initial operations. When necessary adjust it so as to keep it always in an optimum state of tension. Referring to the picture below adjust reduction belt tension as outlined in these steps. A high pitch revving noise from the engine is a sign that the belt has become loose. Be sure to tighten the belt as soon as possible or you could damage it.

1. Remove the propeller from the driven pulley.
2. Loosen the prop shaft retaining nut and then screw (A) NB. They will be very tight!!
3. Insert the 5mm hex key into the hole in the side of the prop shaft. (B)
4. To tension the belt, firmly rotate the shaft clockwise. This in turn will enable the eccentric prop shaft to increase the belt tension. It will be very stiff to move.
5. Once the belt has reached the required tension simply re-tighten the prop shaft retaining screw and nylock nut. (see diagram below for belt tension setting)

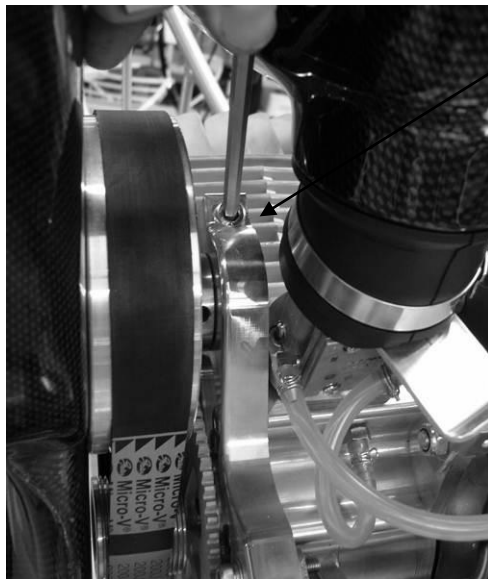

A

**Left:** Prop Shaft retaining screw also has a nylock security nut on the opposite end. Loosen this 4 turns before undoing main screw (A)

**Right:** Use 5 mm hex key provided and slot into drilled hole in propeller shaft. Then rotate propeller shaft hard clockwise to tighten or counter clockwise to loosen.

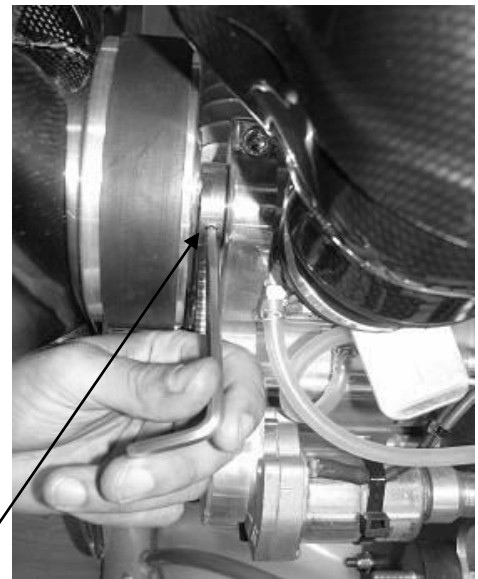

B

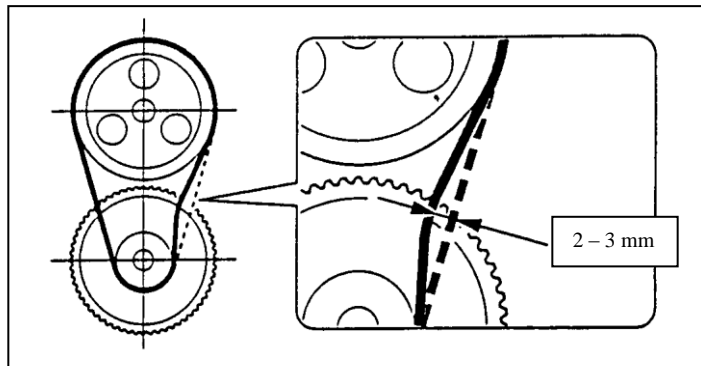

**Left:** Shows correct belt tension. You should be able to push 2 - 3mm movement with your thumb.

## FITTING THE WEIGHT-SHIFT HARNESS

The weight-shift design enables pilots to control flight direction purely by shifting centre of gravity in the harness. To do this simply lean in the desired direction and swing one leg over the other to accentuate the turn. This creates a very efficient smooth turn which requires no brake input.

### Fitting the weight-shift harness:

1. Start by locking the harnesses upper retaining bar onto the chassis as shown below. NB. Ensure Button Clip locates properly and pops into hole as arrowed..

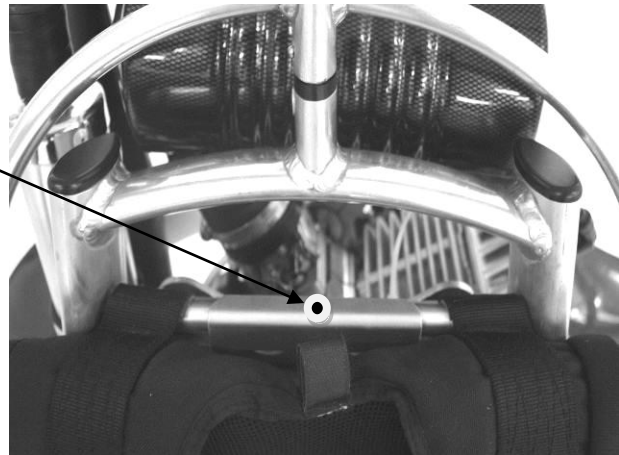

2. At the base of the harness on the reverse side there are 2 steel rings pressed into the webbing tabs. These line up with 2 corresponding M6 threaded inserts located in each chassis upright approximately 10cm from the base.



3. Using the two M6 x 12mm socket screws and large flange washers tighten the harness webbing into position against the chassis uprights.

4. At the front of the harness are 2 webbing loops. Using the stainless steel shackles attached to the swing arms attach the webbing loops to the first hole in the swing arm.

5. Attach carabiner connection points to the corresponding weight setting on the swing arms. (See next page)

## ADJUSTING THE WEIGHT SHIFT HARNESS

To adjust this type of harness to the optimum weight setting, position the hang-point malleon and off-set pin as shown below. The weight ranges are given in the diagram.

**IMPORTANT** – If the harness is not set up correctly it will result in poor handling and uncomfortable flying. It is vital therefore that the steps described below are followed accurately.

**CAUTION!!!** If the pilot is too heavy for the chosen harness setting this will cause the Volution 2 to ride up on the pilots back. This makes for an uncomfortable flying position and also causes the top of the propeller guard to press near to the paraglider brake handles which is potentially very dangerous. If you suspect this it is important that you land as soon as possible and re-set the hang points moving them one or two settings forward.

**NOTE** – Due to the dynamic nature of this harness it may take some flying time to become accustomed to the flying style. It may also take a few flights to decide which hang-point position is most comfortable and effective for you. You will notice that on full power the flying position is more upright and that when you reduce throttle the position is more laid back. The engine off position is designed to be similar to the free flying position which is more comfortable and improves weight shift for thermalling.



(100 – 110kg) (75kg – 90kg) (65kg – 75kg) (55kg – 65kg)

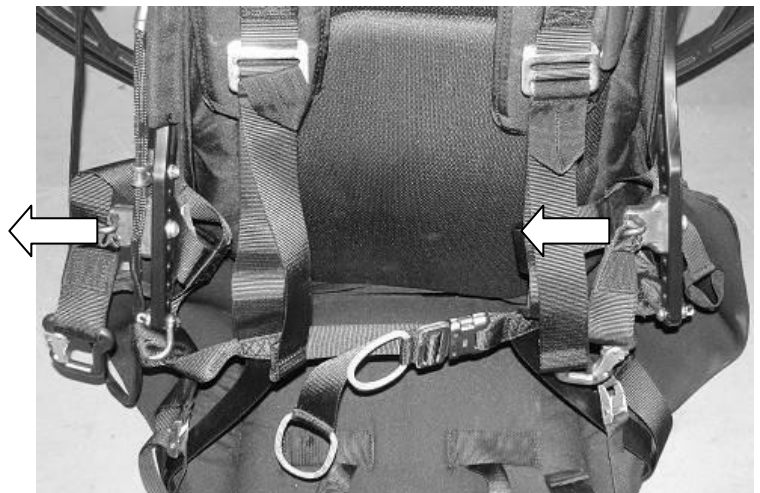

**NB.** The Volution 2 weight shift harness is designed to offset the torque reaction of the propeller. This enables the pilot to fly straight even on full power. The system uses the pilot's weight to counter the torque by off-setting both karabiners to the right as the pilot sits in the harness. See arrows above.

**Important:** Always ensure that both rubber off-set covers are fully tightened in position pointing to the left as you look at the harness before you get in to fly (as above) If you are sitting in the harness they should both point to the right. This is essential!!



WARNING!!! Use of the Parajet powered paraglider is at your own risk.

## MIXING FUEL AND OIL

Use only unleaded regular petrol (95 - 98 octane) and high-grade 2-stroke oil for air-cooled engines. BP Super 2-Stroke and Castrol TTS are recommended. **(North America equivalent is Premium Unleaded (91-93 octane))**.

Other oils can be substituted but any oil used should be for air-cooling chemical synthesis and medium rotation. Check with your manufacturer or our service centres or any authorised Parajet dealer for the best type of oil available in your area.

1. Mix petrol and oil at a ratio of 50:1 (100mm Oil for 5 litres of unleaded petrol)
2. Shake and mix fuel and oil well.
3. Always use freshly mixed petrol and oil not more than 4 weeks old
4. Use standard unleaded fuel (95 – 98 octane is standard)
5. Only use recommended oil.

## FILLING THE FUEL TANK

1. Remove the tank cap. (rotate counter clockwise)
2. Pour the fuel mixture into the fuel tank.
3. Fill tank to 20mm below level of filler (8.5 litres) For maximum flight range fill to the top (3- 4mm beneath cap level total of 9.5 litres)
4. Tighten fuel cap securely. (be sure not to cross thread the cap as it will not seal correctly)

### Note

- Do not fill above this level.
- Be careful of fuel spillage and wipe dry should any occur.
- Be sure the fuel is clean. Although there is a fuel filter in the fuel tank Dirt, dust and other foreign objects can clog the filter and cause the engine to run poorly or stop.

### Caution!

- Never leave the engine running when refueling.
- Observe the 'No Fire' rules; keep all inflammable objects well away from fuel.



## PRIOR TO STARTING THE ENGINE

1. Check carefully the surrounding area before taking out your unit.
2. Be sure to choose a flat bit of ground which is well ventilated. Do not start the engine indoors or other poorly ventilated areas.
3. Be sure nothing is within 3 meters of your unit.
4. Conduct a complete pre-flight check of your unit, especially looking for oil and gas leaks. Check the unit carefully for loose nuts or bolts, bent or damaged frame or any other type of damage.
5. Check level of fuel mixture. Be sure it is freshly mixed (less than 4 weeks old).
6. Check immediate area near the propeller for lines, ropes, clothing and anything that could be caught in the moving propeller or drive pulleys.
7. Pilots with long hair should be especially careful to cover their head.

### Warning!!! - Stay Clear of this Area !!!

- Warn persons nearby before starting the engine- Make it a habit to shout 'Clear Prop' in a loud and clear voice.
- The turning propeller can cause considerable damage and injury.
- Do not start engine indoors or other poorly ventilated areas.
- Be sure area is free from anything that could be entangled in propeller.
- Use only freshly mixed 50:1 regular petrol and oil recommended by Parajet. The most common reason for engine damage is improper oil or petrol
- Only fill tank with the engine off and only after it has cooled down.
- Follow all "No Fire" rules.

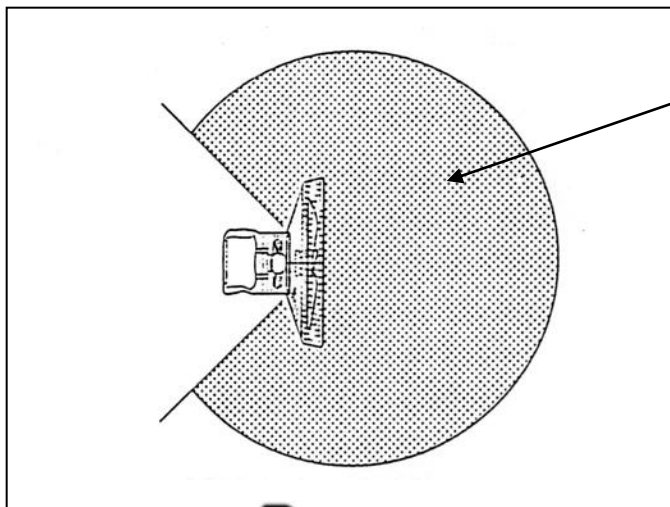

Danger Area. Always ensure this area is clear of people

Warning!!  
Keep clear of moving propeller  
Keep objects away from propeller

## STARTING THE ENGINE

1. Push the choke valve into 'choke' position (closed. See following page for details)
2. Turn on the main switch located at the right side of the electronics case behind the right side of the harness.
3. Make sure the throttle lever is in the idle position, DO NOT GRIP HANDLE.
4. Firmly hold the frame from the harness side. Rest your full body weight against the harness side of the chassis using your shoulder and knee.
5. Hold down the green starter button until the engine fires once.

**Warning: Release green starter button immediately after engine fires once, failure to release immediately will cause the engine to flood.**

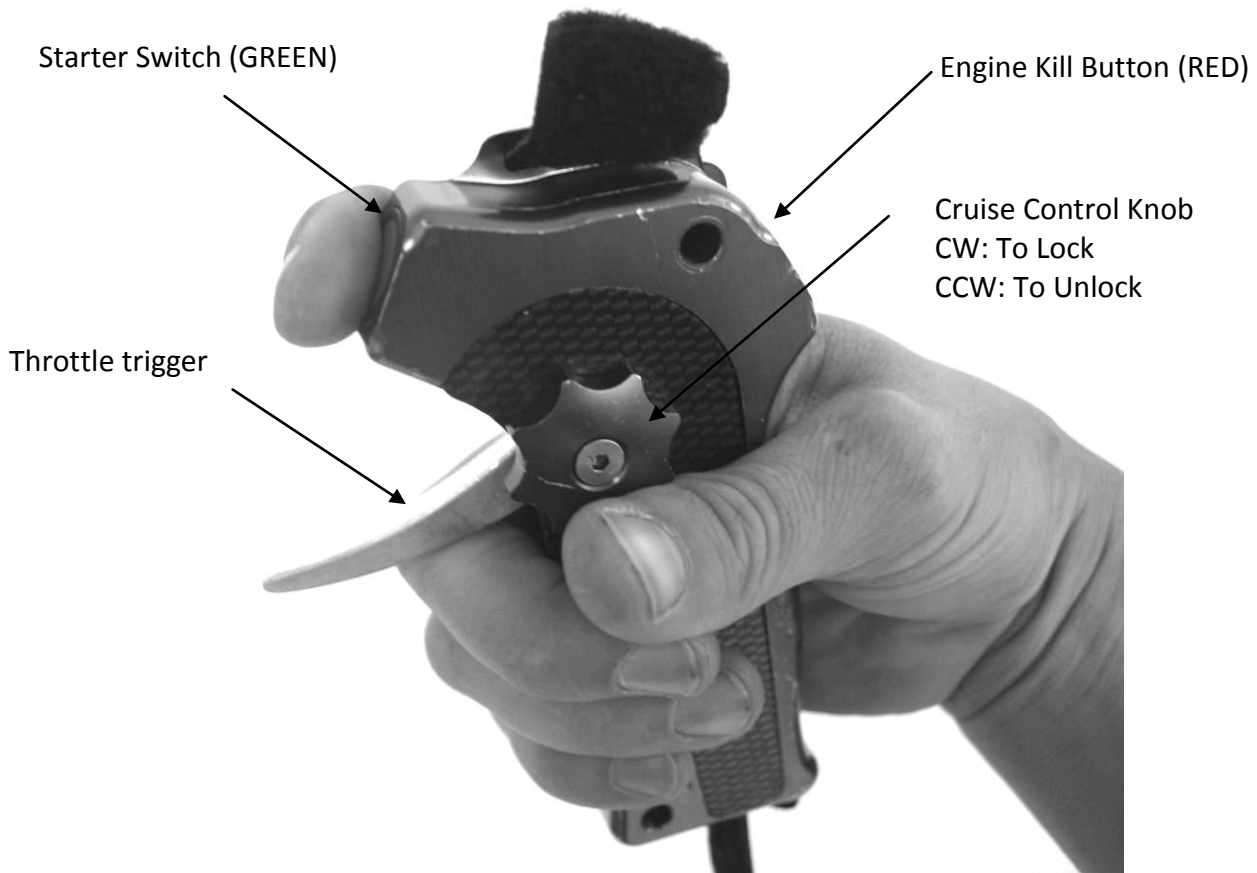

## ACTIVATING THE CHOKE VALVE

6. After first exhaust note is heard, push the choke valve back to its operating position.  
**IMPORTANT! Release the start button immediately after engine fires once or you will flood the engine!!**
7. If the engine fails to start repeat steps 1 to 5 again.
8. After the engine starts, warm it up for two or three minutes at low speed reVolution 2s.(be sure to read the section on engine break-in)



Choke valve shown in “ON” position. Use this position to prime and start the engine initially



Choke valve shown in “RUN” position. Use this position to run the engine for flying

### *STOPPING THE ENGINE*

1. Stop (kill) the engine only after releasing the throttle grip and allowing the engine to return to idle speed.
2. Hold down the Stop button until the engine dies completely.
3. Turn off the Main switch. This cuts power to the starter motor and has been designed as a safety measure. Make it a steadfast rule to turn off the Main Power to avoid inadvertent starts and accidents.

### *RE-STARTING THE ENGINE*

When the engine is warm, leave the choke lever in the operating/open position and follow step 2 through to 7 outlined in the section above ‘Starting the Engine’.

In flight, the pilot can restart the engine when flight conditions are suitable. Be sure the throttle is in idle position when re-starting the engine.

## CARBURETOR ADJUSTMENT

**Warning!** When running the engine on the ground for the carburetor adjustments and checking the thrust power, be sure to place the unit on flat and level ground, rest your full body weight against the chassis, and check the throttle cable is clear of propeller.

The power and idle needles control the lubrication received by the engine. Basic adjustments are made with:

1. Idle adjust screw – clockwise to increase and anti-clockwise to decrease.
2. L-needle - clockwise to decrease mixture flow to carburetor, anti-clockwise to increase flow, (for initial acceleration).
3. H-needle - clockwise to decrease flow, anti-clockwise to increase flow, when throttle is fully open for acceleration.

### Carburetor Details:

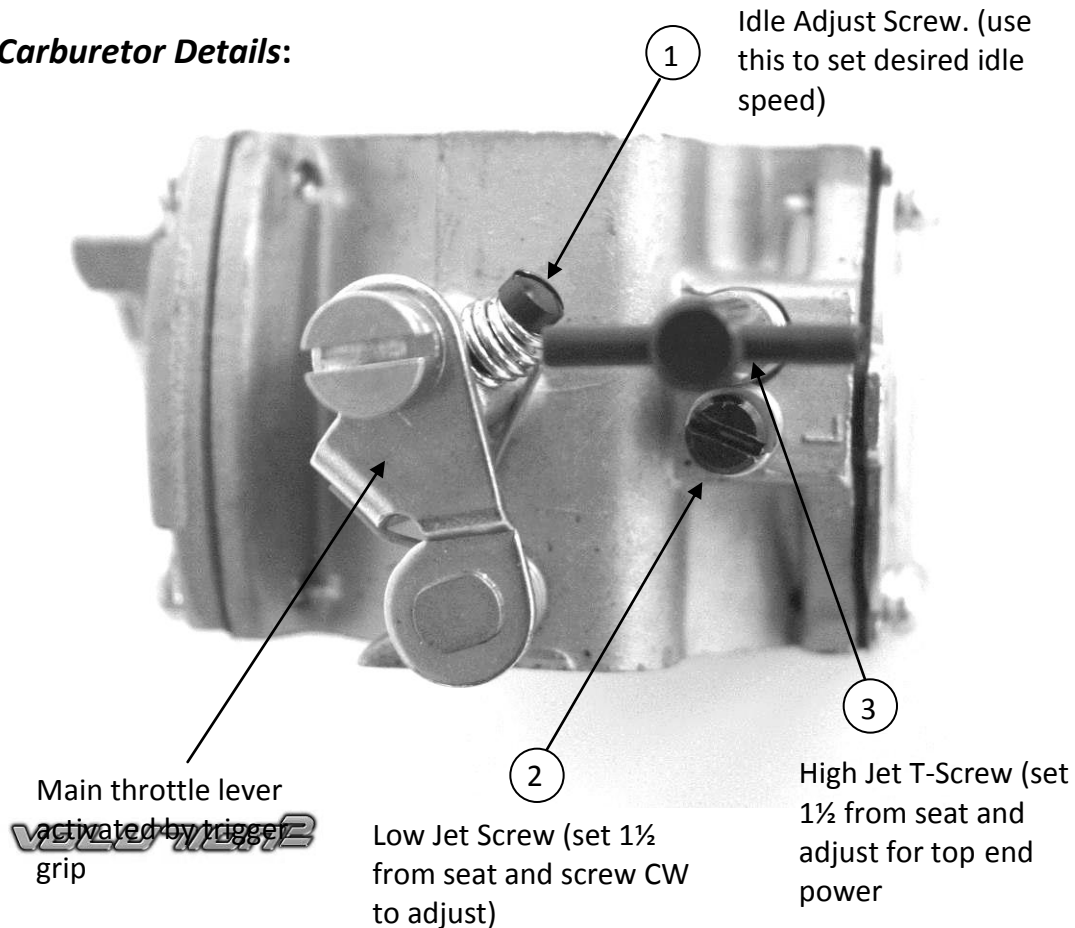

## CARBURETOR ADJUSTMENT (continued)

Note – Adjustments should be done carefully. Warm-up the engine for 3 to 4 minutes before attempting to make any carburetor adjustments. Be aware that changes in the barometric pressure, humidity, and ground altitude affect the carburetor and engine performance.

**Step 1** – With the engine off , start by turning the needles all the way in (clockwise) but do not force them. Check to see that the tension springs are lightly depressed. Then set the Low and High needles at 1 ½ turns front seat. These are factory settings. This puts both on the rich side and leaner adjustments can be made as needed. Any other adjustments should be made to ±½ turns in either direction. Too lean an adjustment can cause improper lubrication and damage the engine.

**Step 2** – Adjust the idle adjust screw to stabilize idle rpm at 2000rpm ± 100. If this setting is too difficult to obtain, turn off the engine and restart before trying again.

**Step 3** – Engage full throttle and check acceleration. If the engine fails to accelerate smoothly or seems to stop, then turn the L-needle ¼ clockwise . Further adjustments by ¼ turn can be made but should this fail to correct the problem then another cause for poor acceleration is suspected (probable). Trouble shoot further or contact your dealer or a Parajet service representative for assistance.

**Step 4** – Adjust the idle adjust screw again to stabilize idle at 2000rpm ± 100. Again engage full throttle for 5 to 10 seconds and return to idle. Repeat Steps 4 and 5 until idle is stable. Do not exceed ½ turn clockwise. The L- needle should always be at least 1 full turn open from seat (CCW).

High Jet T-Bar  
Adjust by hand

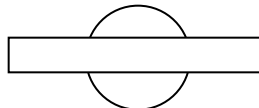

(H) Needle rotate 1/8 turn CW or CCW for top end power

Low Jet Screw  
Use screw driver to adjust

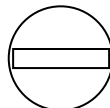

(L) Needle rotate 1/8 turn CW or CCW to set first 70% of rev range. If engine dies when throttle is opened, turn CCW ¼ turn

## CARBURETOR ADJUSTMENT (continued)

**Step 5** – Now Adjust for maximum power at 7600 rpm +/- 100. If max rpm is less than this, turn the H-needle 1/8 turn clockwise. (Parajet Supply RPM Tachometer as an accessory, should you wish to make fine adjustments as described please contact us)

**Caution!!** – Do not close the H - needle (turn clockwise) more than this – 1 and 1/8 turns from seat - overheating from too lean a mixture will cause engine failure or even complete seizure!! It may take some time to find the optimum setting and for the engine to stabilize at high rpm. Carefully observe and judge the best setting of the H – needle. It is safer to error 1/16 or 1/8 CCW and lose 100 to 200 rpm than to tune for more power and higher.

**Step 6** – Again engage full throttle and return to idle. Continue this until the optimum high rpm and stable idle are reached.

**Step 7** – The carburetor is pre-set at the factory before shipment and you should remember that the H - needle should not be adjusted and set for maximum rpm. It is best to find maximum rpm but set the H – needle a few hundred rpm below the peak, in a range close to 7800rpm.

**Note** – Proper carburetor settings can be noticed by inspecting spark plugs after every hour of engine use. A properly adjusted carburetor will reveal spark plug ceramic colour to change from white to a medium brown. A carburetor that is too rich will be black and sooty. Also, numerous oil droplets will appear on the propeller. White or very, very light brown colour reveals too lean a mixture and caution here is advised.

Also pay attention to the reduction belt tension. If the belt is too loose then engine response may seem good but the engine could over-rev to 8300rpm or more. Be sure belt tension is within recommended tolerance (see reduction belt tension adjustment in this manual)

## **ENGINE RUNNING IN PROCEDURE**

The Volution 2 engine undergoes a thorough inspection before shipment during which each engine is run for 1 hour as a preliminary running-in process. For the best engine performance it is necessary to follow our running in procedure during your first 10 hours of flying. This is a simple process and most importantly it means that you can fly your Volution 2 right away with no lengthy ground running process.

For the best results it requires that you never remain on full power for more than 30 seconds at a time during flight.

### **Directions:**

After take-off you may remain on full power during climb out for up to 1 minute (max) It is then important to back-off the power and sit at cruise rpm and fly level for 1 – 2 minutes approx before using full power again.

If you wish to climb high do so in stages climbing on full power for 30 second intervals then allowing the engine to settle at cruising flight rpm or slow climb for a minute or so.

After the first 10 hours of flying you are free to climb using the throttle for longer periods....

### ***However....***

The key to a long lasting, high performance engine is to treat it with some respect. Do not dwell on full throttle for long periods as the engine becomes hot and this reduces the life span of the bearings and mechanical components. As with any engine, using it well within its designed limits ensures that you will receive the longest life from it. Resulting in less maintenance costs and servicing time.



WARNING!!! Use of the Parajet powered paraglider is at your own risk.

## PARAJET VOLUTION 2 SPECIFICATIONS

### Propeller and Cage Guard

Dimensions (Compact)	1090mm cage diameter (98cm propeller diameter/ 38.5 inch)
Dimensions (Macro)	1350mm diameter (123cm propeller diameter/ 48.5 inch)
Material	Aluminium Duralumin 6082 T6

### Engine Specifications

Model	Parajet 172 XT (Manufactured by Parajet)	
Displacement	172cc	
Type	Air-cooled 2 stroke Engine	
Max rpm	7600 rpm	
Fuel	50:1 gasoline/oil	
Capacity (Compact)	9.5 litres	
Capacity (Macro)	11.5 litres	
Starter	Electric	
Propeller	3-blade full carbon fibre Scimitar Design	
Guard	3-piece snap-on, quick assembly system.	
Reduction	2.7 : 1 Compact	3.19 : 1 Macro
Dry weight	26.4kg Compact	27.2kg Macro
Thrust (Compact)	56kg	
Thrust (Macro)	68 kg	
Flight Time (Compact)	2 hours	
Flight time (Macro)	4 hrs	





WARNING!!! Use of the Parajet powered paraglider is at your own risk.

## MAINTENANCE SCHEDULE

### EVERY 5 HOURS

1	Spark plugs	Check colour (white or black) burnt electrode. Connector cap locks with pressure, makes locking sound
---	-------------	---

### EVERY 10 HOURS

1	Air cleaner	Remove and wipe clean. If excessively dirty with carbon and oil then clean with kerosene
2	Air Funnel	Wipe with smooth cloth.
3	Muffler	Check for cracks and loose band or bolts. Run finger inside exhaust pipe –an oily film should be found. No oily film suggests that oil/gas mixture is too lean so the carburettor needs adjusting.

### EVERY 50 HOURS

1	Compression check	Compression in the cylinder must be no less than 1 pound under normal reading.
2	Piston rings	Remove muffler, visual check of rings for stuck or broken areas.
3	Cylinder wall	Check for burns near exhaust port and sides of wall.

## TROUBLE SHOOTING

If any problems occur with your engine you can refer to the following trouble shooting table for correction.

Problem	Check Point	Correction
Engine does not start <ul style="list-style-type: none"> <li>• No spark</li> <li>▪ There is spark but the engine doesn't start.</li> </ul>	<ul style="list-style-type: none"> <li>• The plug cap is disconnected.</li> <li>• The coil wire is not connected to the plug cap terminal.</li> <li>• The plug wire is not connected.</li> <li>• The spark plug is dirty.</li> <li>▪ Fuel does not reach the carburetor. (Check the fuel pipe.)</li> <li>▪ Fuel does not reach the cylinder. (remove the plug and check the plug electrode).</li> <li>▪ Excessive fuel is fed into the cylinder (check the plug electrode.)</li> </ul>	<ul style="list-style-type: none"> <li>• Attach the plug cap.</li> <li>• Connect coil wire to plug cap terminal.</li> <li>• Connect plug wire.</li> <li>• Clean spark plugs or replace them.</li> <li>• Press green starter button again.</li> <li>▪ Press green starter button again</li> <li>▪ Take out plug and press starter several times. (be sure to earth plug)</li> </ul>
There is an initial explosion but the engine does not run continuously.	<ul style="list-style-type: none"> <li>• The choke lever is not set at "driving" position.</li> <li>• The idle screw is not properly adjusted.</li> <li>• The air filters clogged.</li> <li>• The breathers of the fuel cap are clogged.</li> <li>• The fuel filter is dirty.</li> <li>• The L needle of the carburetor is not properly adjusted.</li> </ul>	<ul style="list-style-type: none"> <li>• Set the choke lever to "driving" position.</li> <li>• Make adjustments according to 8 – (1).</li> <li>• Clean air filters.</li> <li>• Clean breathers.</li> <li>• Clean fuel filter.</li> <li>• Make adjustments within the range in 8 - (2)</li> </ul>
The engine does not accelerate through low rpm range.	<ul style="list-style-type: none"> <li>• The choke lever is not set at "open" position.</li> <li>• Warm-up is not sufficient.</li> <li>• The adjustments of the L needle are not proper.</li> </ul>	<ul style="list-style-type: none"> <li>• Set choke lever to "open" position.</li> <li>• Warm up engine.</li> <li>• Make adjustments within the range in 8 – (2)</li> </ul>
The engine does not accelerate through high rpm range.	<ul style="list-style-type: none"> <li>• The fuel filter is dirty.</li> <li>• The breather of the fuel cap are clogged,</li> <li>• H needle adjustments are not proper.</li> </ul>	<ul style="list-style-type: none"> <li>• Clean fuel filter.</li> <li>• Clean breathers.</li> <li>• Make adjustments with range 8 – (2)</li> </ul>
Vibration excessive	<ul style="list-style-type: none"> <li>• Fasteners are loose.</li> </ul>	<ul style="list-style-type: none"> <li>• Tighten fasteners securely.</li> </ul>



WARNING!!! Use of the Parajet powered paraglider is at your own risk.

## **STORAGE FOR A LONG PERIOD AND USE THEREAFTER**

Always follow instructions below after your engine has been stored over a long period.

### **When your engine has not been used for more than 4 weeks**

1. Ideally remove fuel from the fuel tank and replace with fresh fuel for best performance and starting reliability. Older fuel loses a % of volatiles through evaporation even inside the fuel tank (which is marginally porous) and starting the engine becomes more difficult. The exhaust becomes oilier and you may also notice a drop in engine power. Using old fuel will not harm your engine up to about 2 months at which point the properties in the two stroke oil will deteriorate and you will risk damaging the engine through poor lubrication.
2. You may find that the starter battery charge is low, it is important to keep this topped up regularly with the charger supplied. If the battery is low then start charging at least 12 hours before you intend to fly to avoid disappointment as the engine requires a well charged battery to start reliably. The charger can be left connected and charging for up to 4 days with no adverse affect on battery or charger.

### **When the engine is not used for more than 3 months**

1. In order to prevent the piston rings and bearings from rusting, remove the ignition plug and apply a small amount of special purpose oil through the plug hole. After pulling the starter handle several times lightly for lubrication, install the ignition plug back into the engine.
2. After cleaning and drying the various portions of the engine, wrap the engine in a vinyl bag.
3. Store the engine in a dry and well ventilated location away from direct exposure to sunlight.
4. Parajet supplies Briggs and Stratton 'Fuel Fit' it is recommended that you use this additive in your fuel to help clean out the system after a long period of no use. It helps to remove residue in the carburetor and fuel system.



WARNING!!! Use of the Parajet powered paraglider is at your own risk.

***Parajet International LTD***  
***Unit 10 Chaldicott Barns,***  
***Tokes Lane, Semley,***  
***Dorset SP7 9AW***  
***UK***

***Email: [info@parajet.com](mailto:info@parajet.com)***

***Tel: + 44 (0) 1747 830575***  
***[www.parajet.com](http://www.parajet.com)***